



General Description

The Rane SM 82S is a product offering incredible power and versatility. It is the equivalent of a *sixteen* channel mixer in one rack space. Measuring only 5.25 inches deep, it can do the job of mixers costing several times as much while only occupying a fraction of the rack space. It is ideally suited for keyboards, synthesizer expander modules and drum machines, as well as such things as effects mixing in guitar racks. It also functions as an excellent submixer for stereo line inputs and effects to a larger console. Because of shorter internal signal paths, it is much cleaner than many mixers ten times the cost and size.

Each of the eight Stereo (two channel) input channels feature a stereo rotary input Level control, a stereo aux Send level control slider and a left to right Balance control slider. When a single mono input is used, the Balance control acts as a pan pot. The aux return section provides a rotary Return Level control and a

slide control for left to right Balance. The output stage includes a rotary Output Level control and a slide control for left to right Balance.

The human engineering applied to the SM 82S makes it extremely easy to operate. The segregation of function between rotary and slide controls (rotary for all input and output Levels and slide for Balance and Send) makes it simple to use, even in the dark.

The SM 82S is fully expandable using the ¼" TRS Main Expand Input and Output jacks. Expansion is as simple as connecting a stereo ¼" jumper cable from the first unit's Expand Output jack to the second unit's Expand Input jack. Now, two SM 82S units create a 16 channel stereo (32 input) line level Mixer in just two rack spaces. Or, 24 channel stereo (48 input) Mixer in just three rack spaces. You get the idea!

Features

- 8 Stereo Input Channels
- 1 Stereo Auxiliary Send
- 1 Stereo Auxiliary Return
- Stereo Balance / Mono Pan Controls
- Balanced Stereo Output
- Expandable to / from other Mixers
- **New!** Internal Universal Voltage Power Supply (100-240 VAC)



Parameter	Specification	Limit	Units	Conditions/Comments
Input Impedance: Ch's 1-8	100k	20%	Ω	
.....Receive	100k	20%	Ω	
.....Expand	20k	1%	Ω	
Input Level: Nominal	+4	1	dBu	
.....Minimum	-10	1	dBV	
.....Maximum	+26	1	dBu	
Input Design	Unbalanced			
Input Connectors: Ch's 1-8	¼" mono TS (tip-sleeve)			
.....Receive	¼" mono TS			
.....Expand	¼" stereo TRS (tip-ring-sleeve)			Tip=Left; Ring=Right
Input Gain Range	Off to +6	1	dB	
RFI Input Filters	Yes			
Max Output Level: Main	+26 (+20)	1	dBu	Balanced (Unbalanced)
.....Loop Send	+20	1	dBu	Unbalanced
.....Expand	+20	1	dBu	Unbalanced
Output Impedance: Main	100	1%	Ω	Each Output
.....Loop Send	100	1%	Ω	
.....Expand	100	1%	Ω	
Output Design: Main	Active Balanced/Unbalanced			Differential line drivers
.....Loop Send	Unbalanced			
.....Expand	Unbalanced			
Output Connectors	¼" TRS			
Output Gain Range	Off to +6	2	dB	Unbalanced
Frequency Response	20 Hz-20 kHz	3	dB	
THD + Noise	.015	.005	%	+4 dBu, 20-20 kHz
IM Distortion (SMPTE)	.01	.005	%	60 Hz/7 kHz, 4:1, +4 dBu
Input Referred Noise	-112	1	dBu	
Signal-to-Noise Ratio	98 (re +4 dBu, 20 kHz BW)	2	dB	All inputs max, 50% out level, balanced
Crosstalk	76 (1 kHz)	2	dB	Left-Right
	85 (1 kHz)	2	dB	Channel to channel
Overload LED Thresholds	+16	1	dBu	All critical nodes monitored
Agency Listing				UL/cUL/CE
Power Supply Requirement	100 to 240	10%	VAC	50/60 Hz, 7W
Unit: Construction	All Steel			
.....Size	1.75"H x 19"W x 5.3"D			(4.4 cm x 48.3 cm x 13.5 cm)
.....Weight	5 lb			(2.3 kg)
Shipping: Size	4.25" x 20.3" x 13.75"			(11 cm x 52 cm x 35 cm)
.....Weight	8 lb			(3.6 kg)
<i>Note: 0 dBu=0.775 Vrms</i>				

Block Diagram

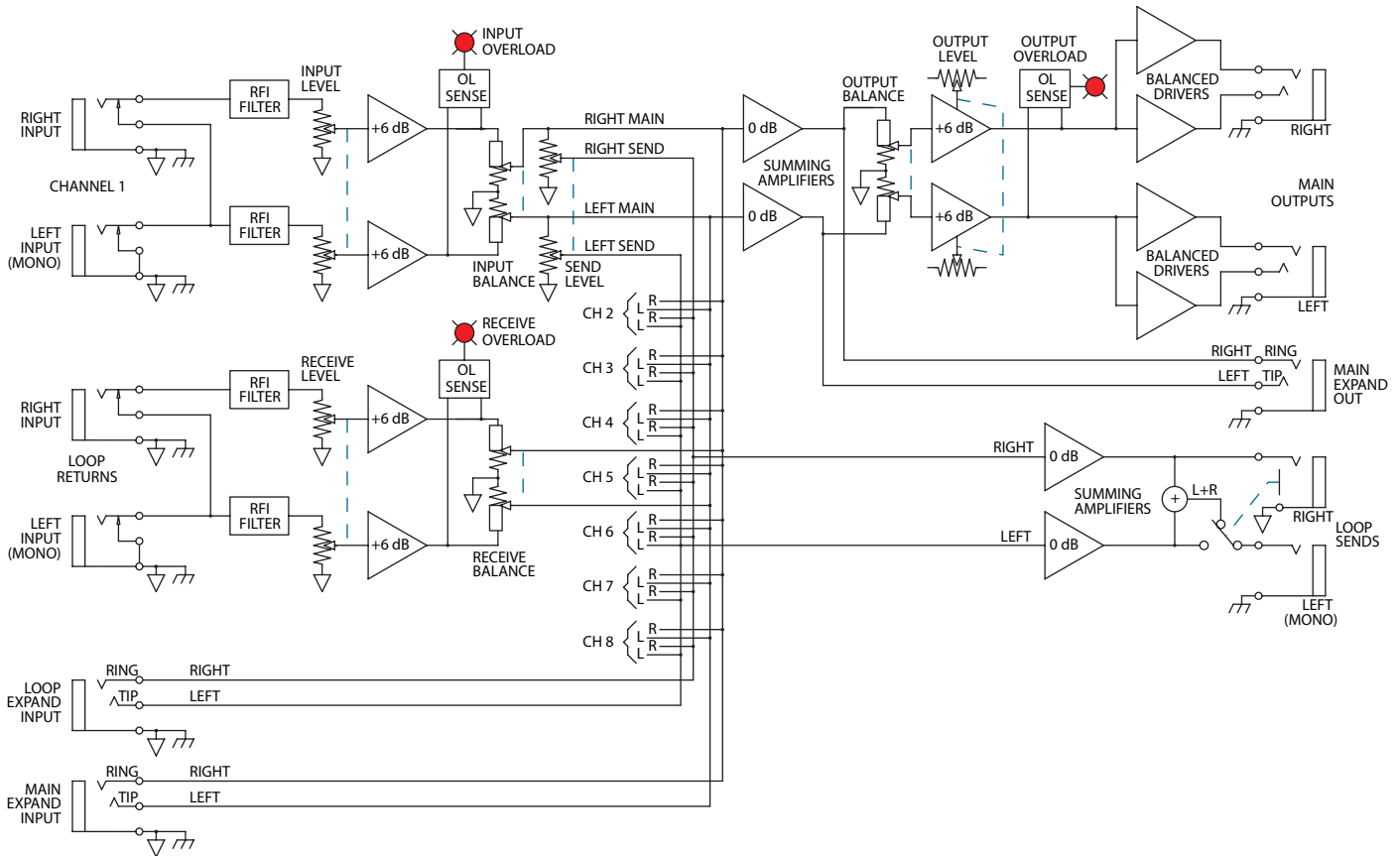

Architectural Specifications

The line level stereo mixer unit shall have eight (8) stereo (total of 16) inputs, one main stereo output pair, one stereo loop send pair, one stereo loop receive pair, loop and main stereo expand inputs, and one stereo main expand output. All inputs, as well as the loop send output, shall be configured such that plugging only into the left input (or output) will mono the system. Each stereo input shall have a rotary ganged level control with a range of off to +6 dB gain and a separate input overload LED. Separate +6 dB gain master rotary ganged stereo output level control shall be provided. In addition, stereo slider-type balance controls shall be provided for all inputs and outputs, along with stereo slider-type send level controls on all inputs.

Complete stereo expansion capabilities shall be provided to allow any number of similar units to be coupled together.

The inputs shall be high impedance (100 k Ω) unbalanced designs terminated with 1/4" TS (tip-sleeve) connectors.

The outputs shall be active differentially balanced with balanced output impedance equal to 200 Ω terminated with 1/4" TRS (tip-ring-sleeve) connectors. RFI filters shall be provided.

The unit shall be capable of operation by means of its own built-in universal power supply operating at 100-240 VAC and meet CE requirements. The unit shall be UL and cUL listed. The unit shall be constructed entirely from cold-rolled steel, and mount into a standard EIA relay rack occupying 1 rack-space.

The unit shall be a Rane Corporation Model SM 82S.

SM 82S

STEREO LINE MIXER



Rear Panel

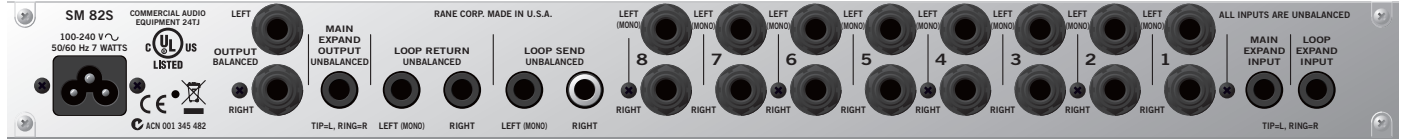

Home Studio Example

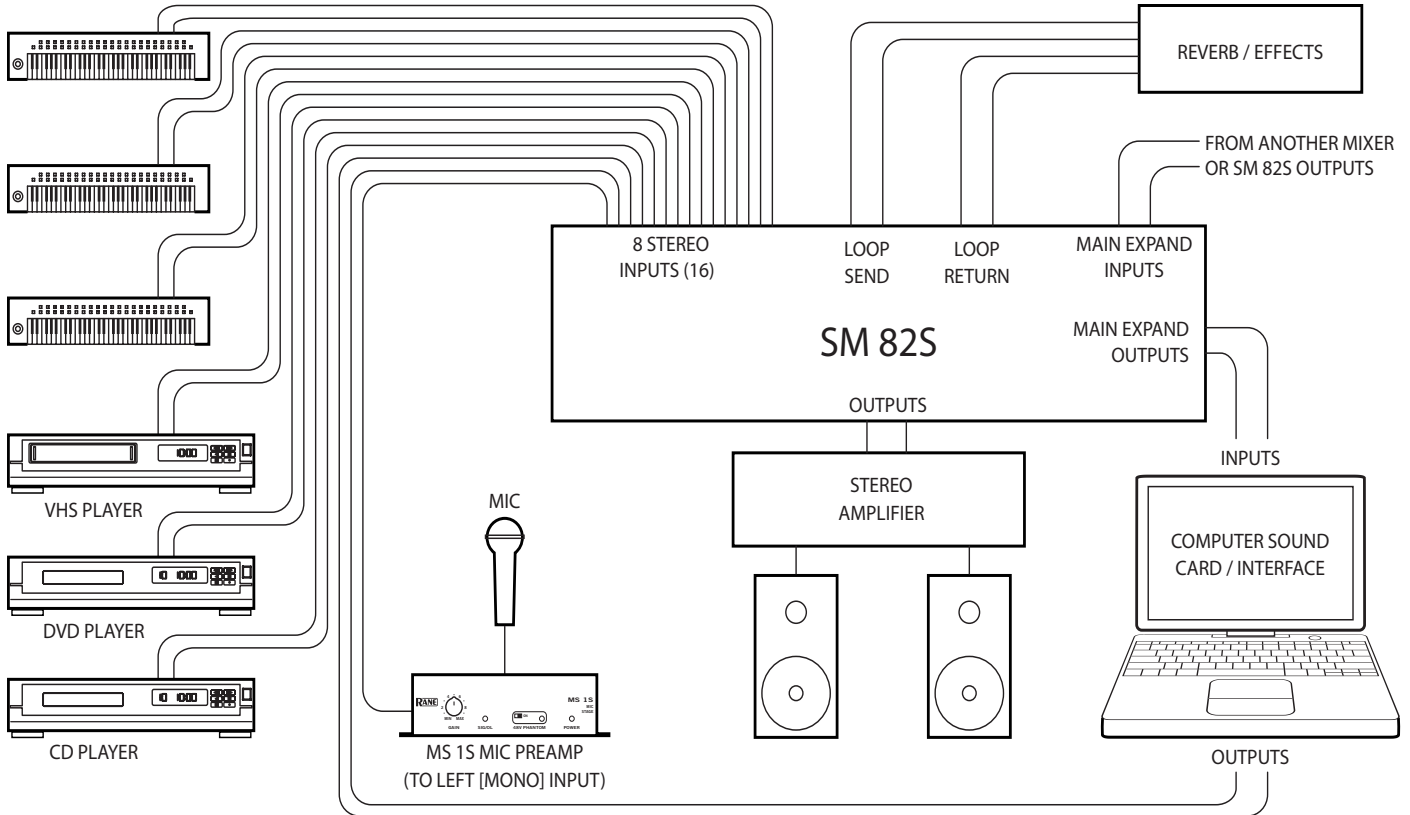

Application Information

The SM 82S allows you to mix eight Stereo line level Inputs down to a main Stereo Output. Additionally you can create a separate Stereo Loop Send mix for driving any stereo, or mono, external processor, and then return from this processor into the Stereo Loop Return Inputs. The stereo Return Level control is used to set the desired mix of wet and dry signals.

For applications not requiring the looping facilities, the Loop Return Inputs double as a fully functional 9th Stereo Input, creating a 9-Input Stereo Mixer! When used this way, the Loop Send Outputs become a separate Stereo Output pair, useful for monitor sends, tape outputs, or any other application.

When not used for expansion, the Main Expand Output pair double as a pre-fader stereo mix, again useful as tape outputs, or any other fixed-level application.

Mono sources and external processors are handled easily by the SM 82S. Connecting only to any Left Input Jack automatically routes this signal to the Right channel so an equal Left/Right signal is summed into the mains. Similarly, connecting only to the Left Loop Send output gives you an equal mono L+R output send for mono input processors.

The question arises regarding mic levels. Since the SM 82S operates only at line levels, microphone applications require separate boosting before connection. Rane offers a mic stage model MS 1S ideally suited to this application.

Available Accessories

- SC 1.7 Security Cover
- MS 1S Microphone Preamp