

## High Fidelity RPMs: Multi-Zone, Multi-Source Record Store

### Before You Begin

The Storage (offline) configurations for all of the examples discussed in this article are available from Rane's website (<http://www.rane.com>). Download or copy these files to your computer, and add them to a new or existing Project.

*NOTE: Drag Net 2.0 or higher is required to view these device configurations. The latest version of Drag Net can be downloaded from <http://www.rane.com/dragnet.html>*

To add Storage configurations to a Project:

- 1) Right-click anywhere within the Project window and choose **Add File(s)**.  
  
- or -  
  
Click on the **File** menu, choose **Project**, then select **Add File(s)**.
- 2) Browse to the location of the Application Example files (.rx file extension, where xx is the device type - .r88 for RPM 88, as an example) on your hard drive.
- 3) Select one or more of the files from the list, then choose **Open**. The configurations then appear as entries under the Storage folder of the Project window.

### Drag Net Files Required

- RecordStore\_1.r88
- RecordStore\_1.r88.mem
- RecordStore\_2.r88
- RecordStore\_2.r88.mem

### Concepts Presented in this Example

- Using the AES3 digital I/O to expand a system across two units.
- Preset overlay of parameters to do independent source selection within each zone.
- Controlling multiple Levels with a single remote.
- Custom mapping SR 3 Remote Pages to specific Presets.
- Scaling the operating range of Level controls.



## Problem

A large record store is divided into six zones. Five of the zones are stereo left/right, with a separate mono subwoofer. The sixth zone is a simple mono feed to the ubiquitous in-store coffee shop. Four stereo sources (8 inputs total) are available as inputs to the system: Satellite music service, DVD Jukebox, CD Jukebox, and a special Room Feed (XLR connectors on the wall) for connecting to a mixing console when bands or DJs drop by for in-store appearances.

Signal processing, independent source selection and Level control within each zone are required.

## Solution

Two RPM 88s are used to handle all system EQ, Compression, Limiting, and remote Source Selection and Level control (see the system block diagram). The eight audio source outputs are paralleled across the inputs of both RPM 88s. Each RPM 88 handles three of the six zones. RPM 88 #1 handles Zone 1 (L/R/Sub), Zone 2 (L/R/Sub) and Zone 3 (L/R only). RPM 88 #2 handles Zone 4 (L/R/Sub), Zone 5 (L/R/Sub), the coffee shop (mono), and the subwoofer output for Zone 3. Zone 3 is a bit of an anomaly because its outputs are split across two RPMs. We'll talk about the reasoning behind this arrangement in just a moment.

The Drag Net device configurations are straightforward – 3-band PEQ and compression on each input; source selectors, 6-band PEQ, level control and limiting for each zone output. Even with all of this processing in place we still haven't maxed out the available DSP resources!! That means there's plenty of horsepower left over for additional EQ, or for using delays to time align adjacent zones.

### **AES3 Digital I/O: More than just a pretty interface.**

Q: "Why the heck are the Zone 3 outputs split across multiple RPMs?"

A: Each zone (with the exception of the coffee shop) requires three outputs: Left, Right and mono Subwoofer. Hmm...three outputs per zone times three zones per RPM 88 equals nine outputs. That's one output more than the RPM 88 provides – or is it?

The RPM 88 features a two-channel AES3 digital output in addition to the eight analog outputs. For this system design we've opted to connect the AES3 digital output of RPM 88 #1 to the AES3 digital input of RPM 88 #2, essentially creating a simple, one-channel expansion bus (Figure 1). An unused analog output on RPM 88 #2 handles the subwoofer output (Figure 2). Another option would have been to use an external AES3 digital-to-analog converter (e.g., a Radio Design Labs RU-AEC1) and treat the AES3 output as simply another analog output. For accuracy's sake Delays are used on the Left and Right channels to account for the additional millisecond or so of propagation delay the Subwoofer feed experiences given this arrangement.



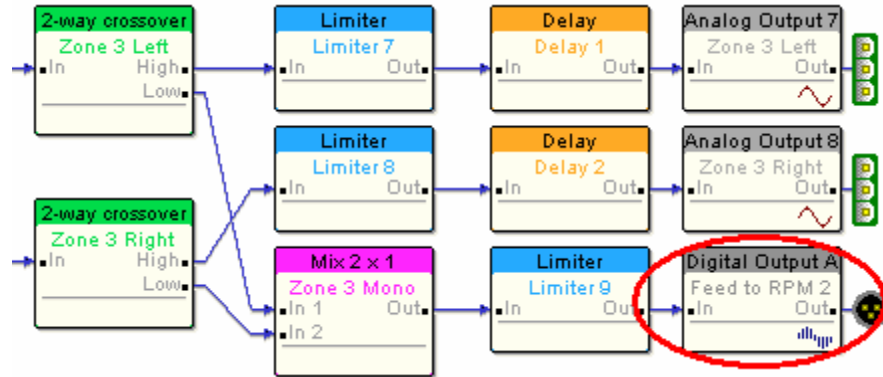

- Figure 1 RPM 88 #1 Config (RecordStore\_1.r88). Zone 3's Mono subwoofer feed is wired to one channel of the AES3 digital output, which in turn connects to the AES3 digital input of the second RPM 88.

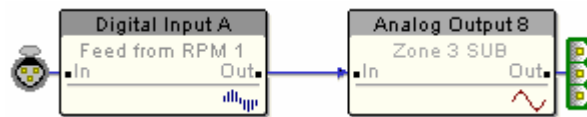

- Figure 2 RPM 88 #2 Config (RecordStore\_2.r88). One channel of the AES3 digital input connects directly to an unused analog output, negating the need for an external D/A converter.

### Building the Presets

Within each zone the user must be able to select any of the audio sources, completely independent of the currently selected source in any other zone. To accomplish this grand feat four Presets are required for each zone – one Preset per audio source. Thus a total of 12 Presets were created within each RPM 88 (3 zones per RPM 88).

Each Preset contains only the Source Selector blocks *of the zone we're interested in*. Recalling a Preset for Zone 1 has no effect on the current selection for Zone 2 or Zone 3, due to the way in which Presets “overlay” working memory within the RPM. For more information on Presets and how they affect the current working memory of a Drag Net device see the Application Example “Power of the Preset Overlay: Limiting User Access to Parameters” (<http://www.rane.com/dnapps.html>).

Click on the **Recall Preset** button on the RPM toolbar and choose **Recall Preset 1**. Note how the Preset block list contains only the source selectors for Zone 1 (Figure 3), and how the corresponding blocks on the Processing Map now have small, numbered tags in their lower right-hand corner, indicating they are part of the most recently recalled Preset (Figure 4).



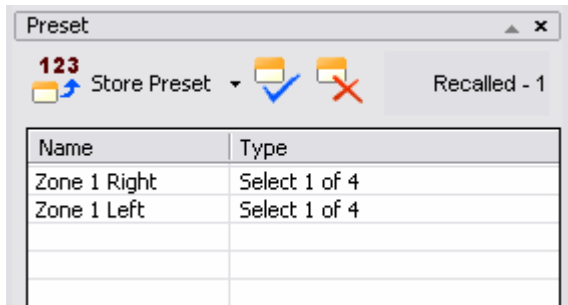

■ Figure 3 Preset Block List after recalling Preset 1. Only the Zone 1 Source Select blocks are included as part of the Preset.

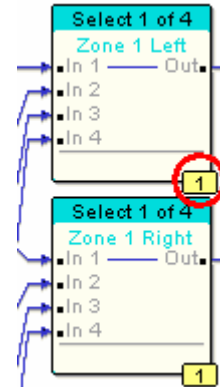

■ Figure 4 Blocks contained in the Preset are "tagged" on the Processing Map.

Recall Presets 2 through 4 to see the remaining source selections for Zone 1. Now recall Preset 5, noting that the Preset Block List contains only the source selectors for Zone 2. In the actual installation SR 3 Smart Remotes are used to recall Presets. An upcoming section discusses how these Presets are assigned to specific pages of the SR 3 remotes. The entire list of Presets is as follows:

■ Table 1 Presets and SR 3 Page Assignments

	SR 3 PAGE	RPM 88 #1			RPM 88 #2		
		Preset Assignment			Preset Assignment		
		SR 3 #1	SR 3 #2	SR 3 #3	SR 3 #4	SR 3 #5	SR 3 #6
Select Satellite	1	1	5	9	1	5	9
Select DVD	2	2	6	10	2	6	10
Select CD	3	3	7	11	3	7	11
Select Room Feed	4	4	8	12	4	8	12
		Zone 1	Zone 2	Zone 3	Zone 4	Zone 5	Coffee Shop

**Assigning Remotes to Levels: Power to the People – but not too much...**

Click on the Remote Map tab at the bottom of the Device Configuration window to display the current Remote Group Assignments (Figure 5).



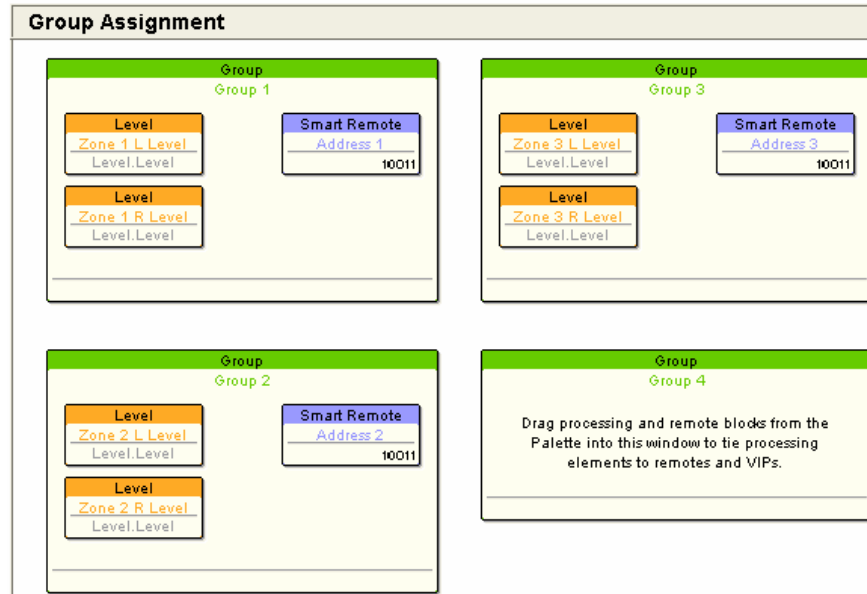

■ Figure 5 RPM 88 #1 Remote Map Group Assignments.

The SR 3 Smart Remote within each zone is grouped with both the Left and Right Levels for each zone, allowing the user to change both Levels simultaneously from a single remote control while maintaining the proper Left/Right balance.

Double-click one of the Smart Remote blocks on the Remote Map to display the Remote's Properties dialog (Figure 6). This dialog allows you to define a custom mapping of SR 3 Remote pages to specific Presets within the RPM. For this installation we want all remotes to display the same selection options (Page 1 of the SR 3 selects Satellite, Page 2 selects DVD, Page 3 selects CD, Page 4 selects Room Feed), but have each remote access a different range of Presets (Figure 7) as previously discussed (see Table 1). The **Max Num Pages** parameter has been set to 4 so the user doesn't have to scroll through any of the remaining Unassigned pages.



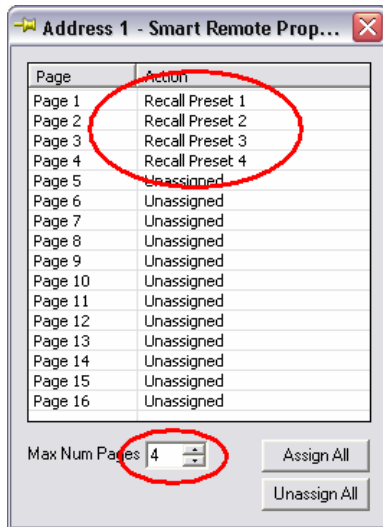

- Figure 6 SR 3 #1 Maps Pages 1 through 4 to Presets 1 through 4 for source selection in Zone 1.

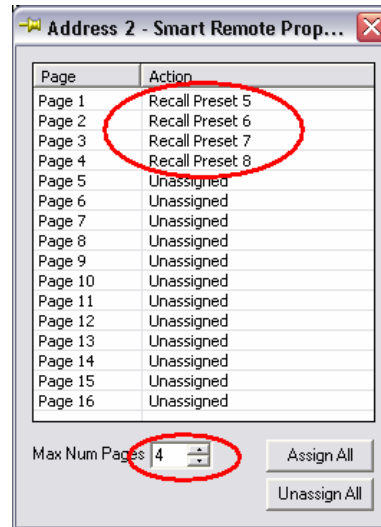

- Figure 7 SR 3 #2 Maps Pages 1 through 4 to Presets 5 through 8 for source selection in Zone 2.

One last thing before we leave the Remote Map. Since this *is* a record store, it will likely be staffed with at least one person who has a love of music and a disregard for loudspeakers. Double-click on a Level block in one of the Groups on the Remote Map to display that block's Properties dialog. This dialog allows you to scale the operating range of a remote (SR 2, SR 3, or even a "pot-on-a-wall" connected to a logic input) to a user-defined Level (dB) range (Figure 8). To keep folks in line we set an upper range Maximum of 6 dB, which means the full clockwise position of the remote now corresponds to a maximum Level increase of 6 dB. Think of it as a good first line of defense, with the Limiter immediately before the output as a backup to handle the most extreme situations (you put the Limiter after the level control, didn't you?).

The **Off at Minimum** parameter dictates how the Level control responds to the lower extreme of a remote's control range. If this box is checked, the remote's minimum position (typically fully counter-clockwise) completely mutes the signal; otherwise, the signal is attenuated to the value set by the **Minimum** parameter. We want music pumping 24/7, so we'll leave this box unchecked.

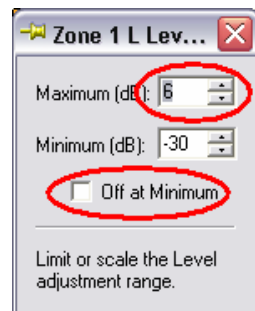

- Figure 8 Level block Properties dialog showing scaling of remote Max/Min range and Off at Minimum parameter.



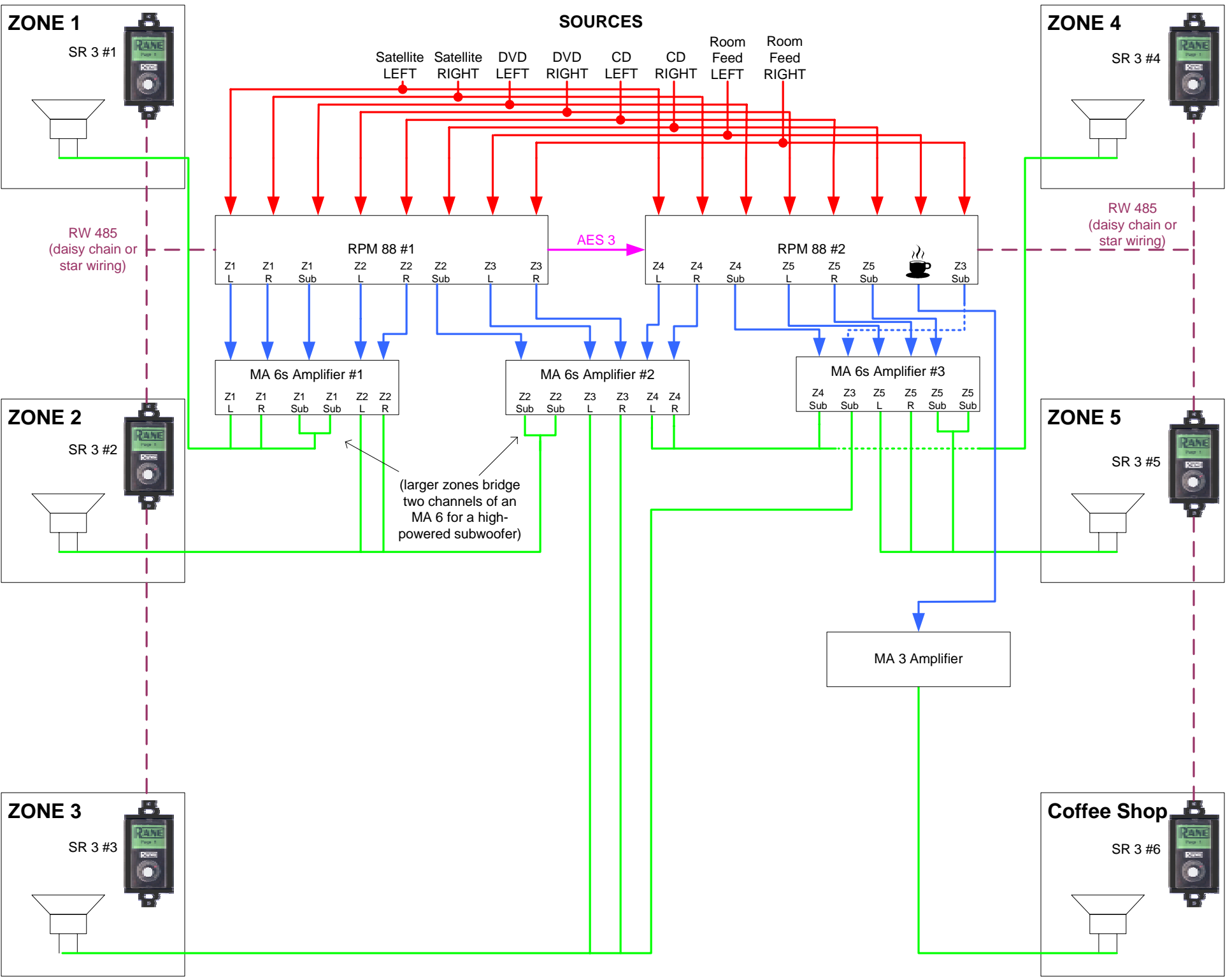

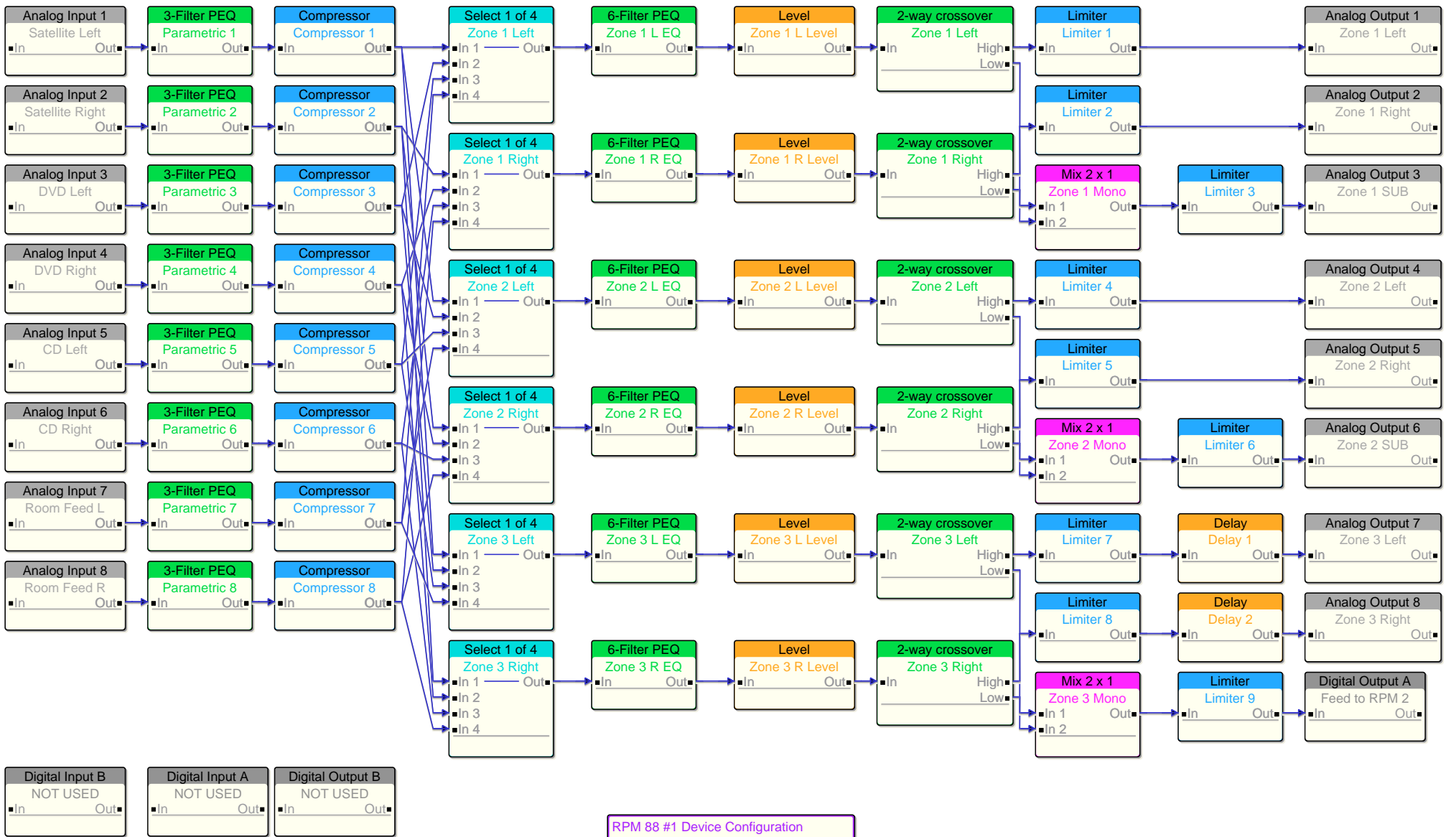

RPM 88 #1 Device Configuration

Files:  
 RecordStore\_1.r88  
 RecordStore\_1.r88.mem

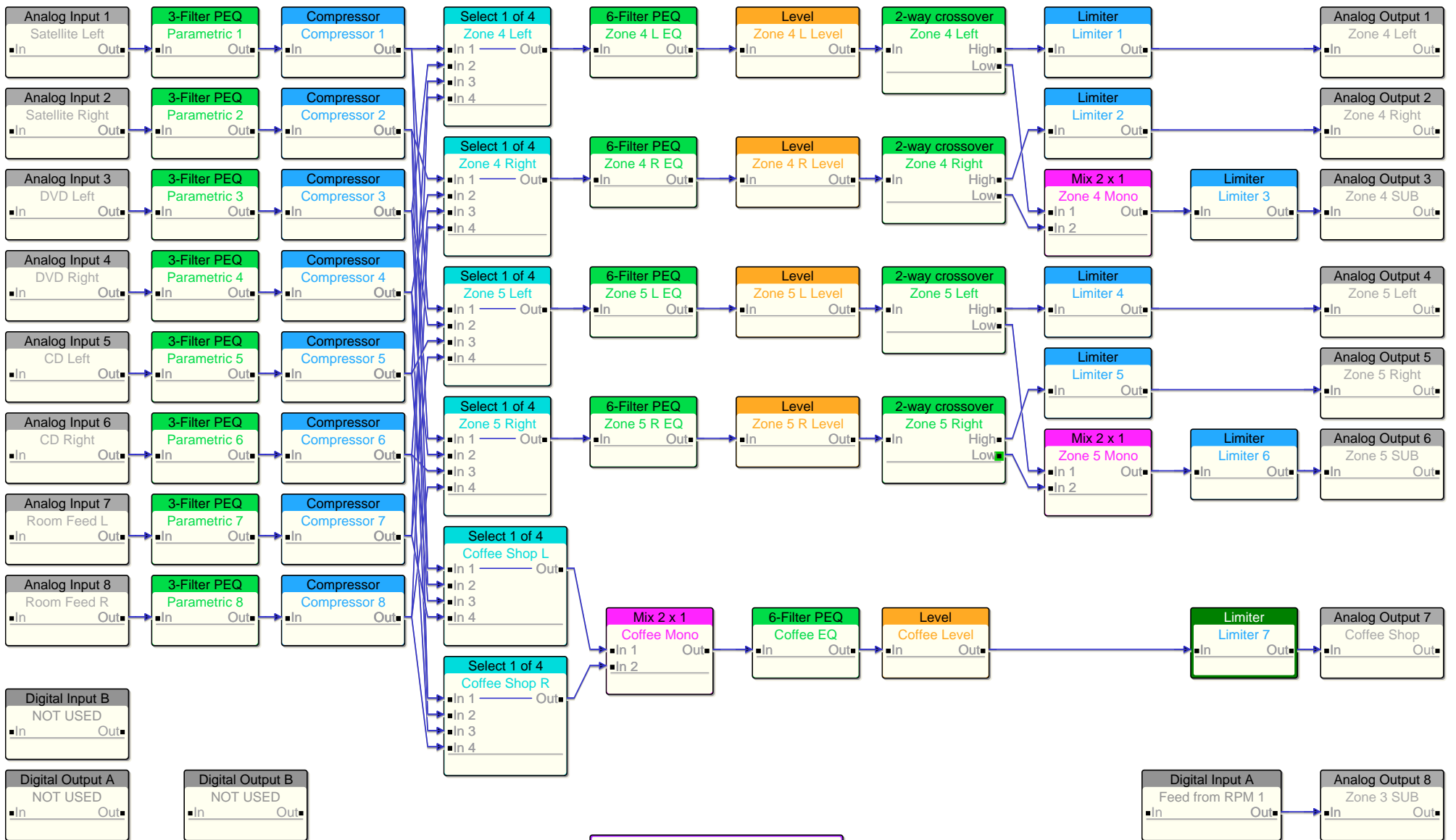

RPM 88 #2 Device Configuration  
 Files:  
 RecordStore\_2.r88  
 RecordStore\_2.r88.mem